

Instruction Manual

nXDS Replacement Tip Seal Kit

| Description | Item Number |
|-------------------------------|-------------|
| nXDS Replacement Tip Seal Kit | A735-01-801 |

| Products Applicable to: | |
|-------------------------|-------------|
| nXDS6i | A735-01-983 |
| nXDS10i | A736-01-983 |
| nXDS15i | A737-01-983 |
| nXDS 20i | A738-01-983 |
| nXDS6iC | A735-02-983 |
| nXDS10iC | A736-02-983 |
| nXDS15iC | A737-02-983 |
| nXDS20iC | A738-02-983 |
| nXDS6iR | A735-03-983 |
| nXDS10iR | A736-03-983 |
| nXDS15iR | A737-03-983 |
| nXDS20iR | A738-03-983 |



Important safety Information

- Vacuum pumps are potentially dangerous if incorrectly used, repaired or maintained, so please approach the repair or maintenance with caution.
- Any incorrectly fitted spare parts could damage your pump and could be potentially dangerous.
- Never allow unqualified personnel to attempt to remove or replace any part of the pump.
- If you have any doubts about the servicing procedures or the products capabilities please contact Edwards.
- Before returning any equipment to Edwards for repair please follow the Edwards HS1 procedure and complete an HS2 declaration form to warn of any substances used or produced in the equipment that can be dangerous. The procedure and forms are included with the pump instruction manuals and can be downloaded together with Edwards local contact details from www.edwardsvacuum.com
- Always conform to service schedules unless adverse conditions necessitate more frequent servicing.
- Report any defect before an accident or consequential damage can occur.
- Observe local and country specific regulations, norms and guidelines.
- Never allow anyone to remove large or heavy components without adequate lifting equipment.
- Before maintenance work is begun, ensure the pump is switched off and isolated from the mains.
- The pump may have been exposed to processes which use hazardous substances or produces by-products which are dangerous to human health and safety, for example, chemically active, biologically active or radioactive substances.
- Before working on a pump, ensure that the correct personal protective equipment is available and being used. Always wear safety goggles. Wear a breather mask with positive air pressure and take other precautions if you believe the pump may be contaminated with hazardous substances and dusts.
- When applying sealants and lubricants, prevent contact with the skin by wearing suitable gloves.
- Seals may contain fluoroelastomer, which when properly handled is not dangerous but which may produce a toxic and corrosive residue (hydrogen fluoride or hydrofluoric acid) in the event of excessive heat or fire depending on the circumstances of degradation and other materials involved.
- On completion of maintenance, check the pump functions correctly and that all guards and protection devices are fitted and working correctly and that the pump is electrically safe.
- If the pump is used for handling hazardous substances check the pump for leak-tightness before use.
- Dispose of waste oil and any process by-products in accordance with local and national safety and environmental requirements. It is usually illegal to dispose of waste oil into drains or water courses, or to bury it.

Contents

| Section | Page |
|---------------------------------------------------------------------------|------|
| 1 Replace the tip seals | 1 |
| For return of equipment, complete the HS Forms at the end of this manual. | |

Illustrations

| Figure | Page |
|---------------------------------------|------|
| 1 Fan cowl removal | 1 |
| 2 Tip seal fitting | 2 |
| 3 Tip seal fitting | 3 |
| 4 Tip seal finish mark | 3 |
| 5 Motor fan lead connector | 4 |
| 6 Pump side views | 4 |
| 7 Replacing the tip seals | 5 |

Associated publications

| Publication title | Publication number |
|-------------------|--------------------|
| nXDS Scroll Pump | A735-01-880 |

This page has been intentionally left blank.

1 Replace the tip seals

Replace the tip seal as described below. Prepare the pump by running on gas ballast control for one hour to remove any process gases.

1. Switch off the pump and isolate from the electrical supply.
2. Undo the two screws (Figure 1, item 1) which secures the fan cowl and remove.
3. Undo the four screws (Figure 7, item 6) which secures fixed scroll assembly to the housing assembly.
4. Carefully separate the fixed scroll assembly from the housing assembly using a suitable lever in the slots provided (Figure 6).

Figure 1 - Fan cowl removal



CAUTION

Take care when separating the fan-cowl/fixed scroll assembly from the housing assembly. The motor fan lead must be disconnected from the controller before the fan-cowl/fixed scroll assembly can be fully removed (Figure 5).

5. Starting from one end, remove the tip seal from the fixed scroll. Repeat this operation for the orbiting scroll (Figure 7, item 2). Remove the fixed scroll O-ring (Figure 7, item 3). Dispose of all used items that have been removed following this operation.
6. Using a clean dry lint-free cloth and IPA, remove all dust and process debris from the scroll forms and grooves. Heavier process can be removed with Green Scotch Brite® only.
7. Taking a new tip seal, fit it using the following technique in both the orbiting scroll and the fixed scroll:
 - Starting at the centre of the scroll form, insert the tip seal into the tip seal channel. Ensure that each tip seal starts as close as possible at the start of the scroll channel. (Figure 3).

Note: The nXDS20i has multiple tip seal starts in both the Orbiting and Fixed scrolls.

- Continue to push the tip seal into the tip seal channel while working your way around the channel profile until you have reached the end. Ensure the tip seal is pressed squarely and fully home at each pinch point, these are located closer to the centre of the scroll.

Figure 2 - Tip seal fitting

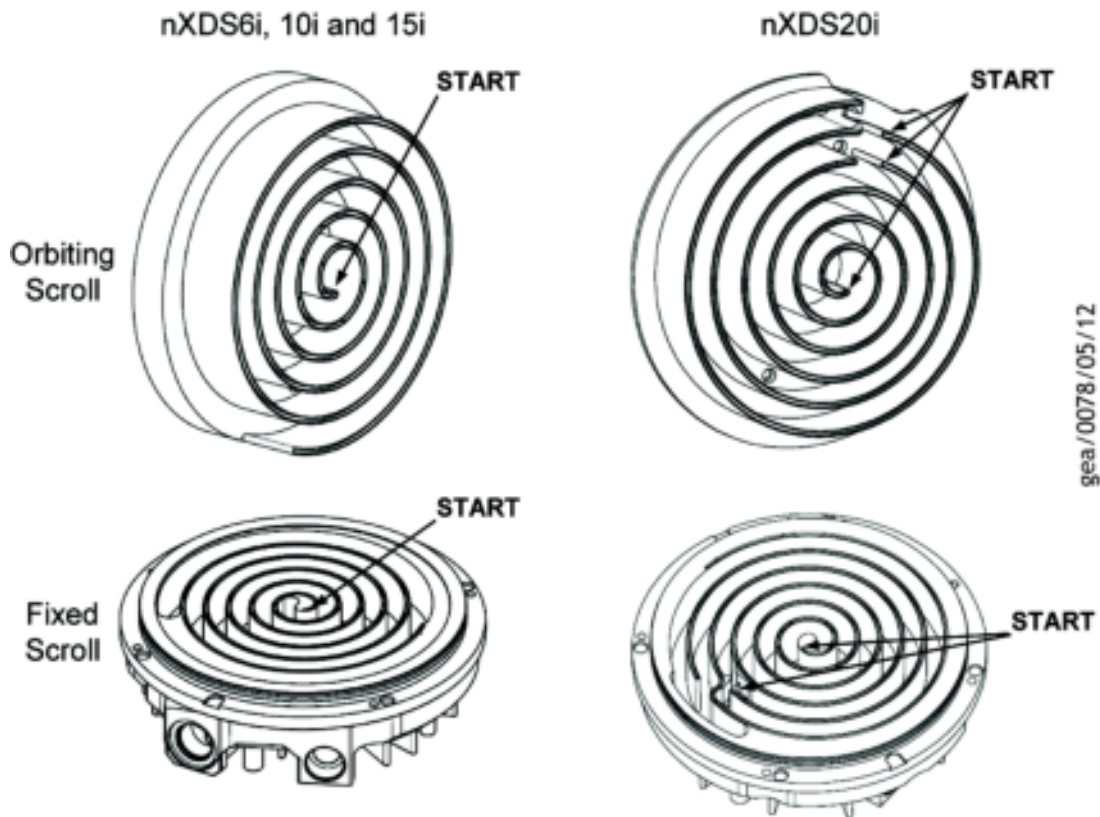

- Cut short the tip seal at the end of the scroll channel. There should be at least 20 mm between the end of the channel and the tip seal, this is to allow for expansion.

Note: A mark is provided at the end of all the tip seal channels to indicate where to cut the tip seal (Figure 4).

- Remove any tip seal debris which may have been produced while inserting the new tip seals.
8. Fit the new O-ring onto the fixed scroll. The O-ring may be moistened with water (H₂O) only, to aid assembly (Figure 7, item 3).
 9. Stand the pump on its end and carefully offer the fan cowl/fixed scroll assembly up to the housing assembly. Connect up the motor fan connector into the controller mating connector (Figure 5).
 10. Assemble the fan-cowl/ fixed scroll assembly onto the housing assembly by hand using even downward pressure.

CAUTION

Check that the alignment dowel (Figure 7, item 8) in the housing assembly lines up with the hole in the fixed scroll. Ensure that the fixed scroll is fitted squarely onto the housing assembly.

11. Tighten the fastening screws in small increments (Figure 7, item 6) and pull-up evenly the fan-cowl/ fixed scroll assembly onto the housing assembly. Torque each screw to 9 Nm.

Note: Care must be taken not to damage or trap the O-ring.

12. Rotate the pump by hand using a 4 mm Allen key.

CAUTION

The fan-cowl/fixed scroll assembly must be fitted evenly while tightening each screw, do not start by assembling one side first.

13. Reinstall your pump in accordance with Section 3 of the nXDS Scroll Pump manual A735-01-880.

14. When operating your pump following a tip seal change, ensure the fan is operating correctly.

Note: The pump tip seals may take a few hours to bed-in before full performance is restored.

Figure 3 - Tip seal fitting

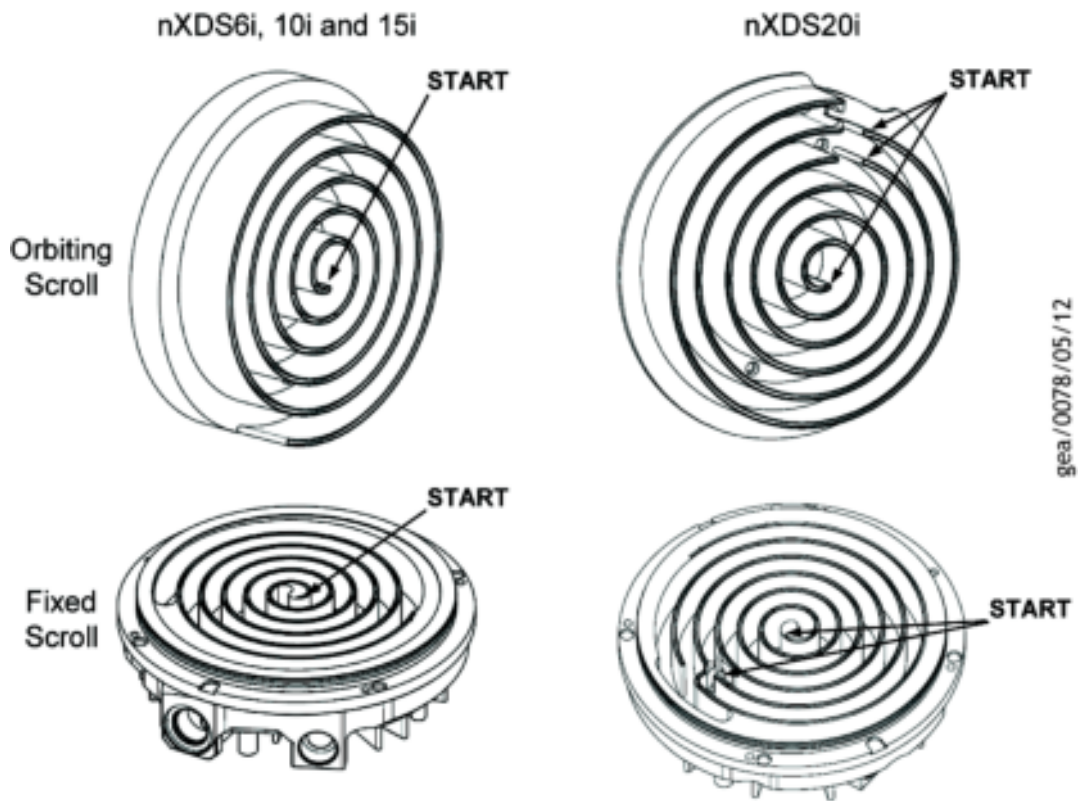

Figure 4 - Tip seal finish mark

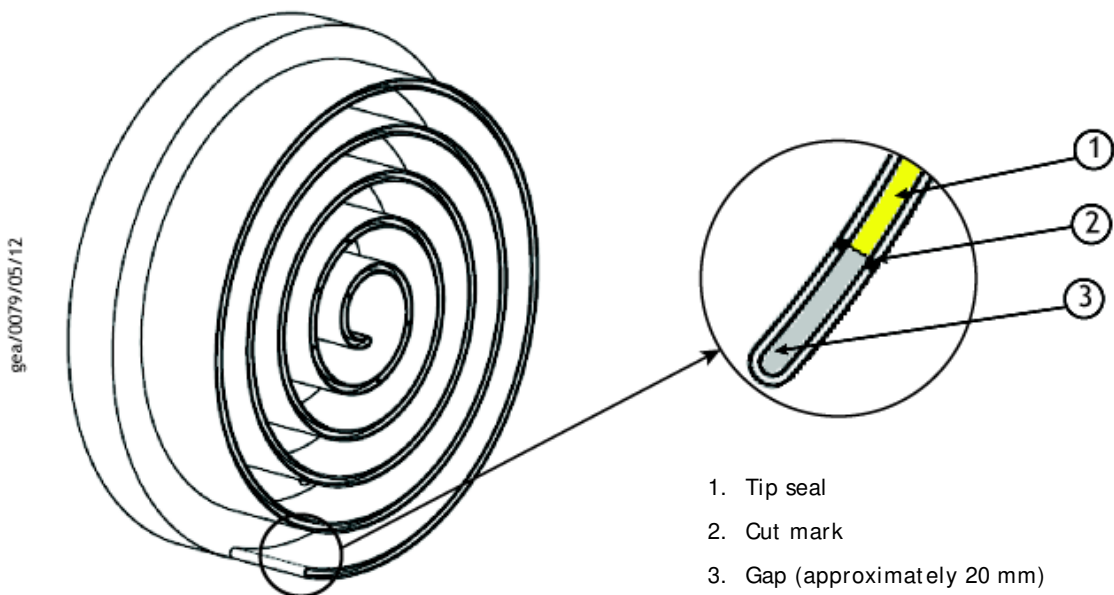
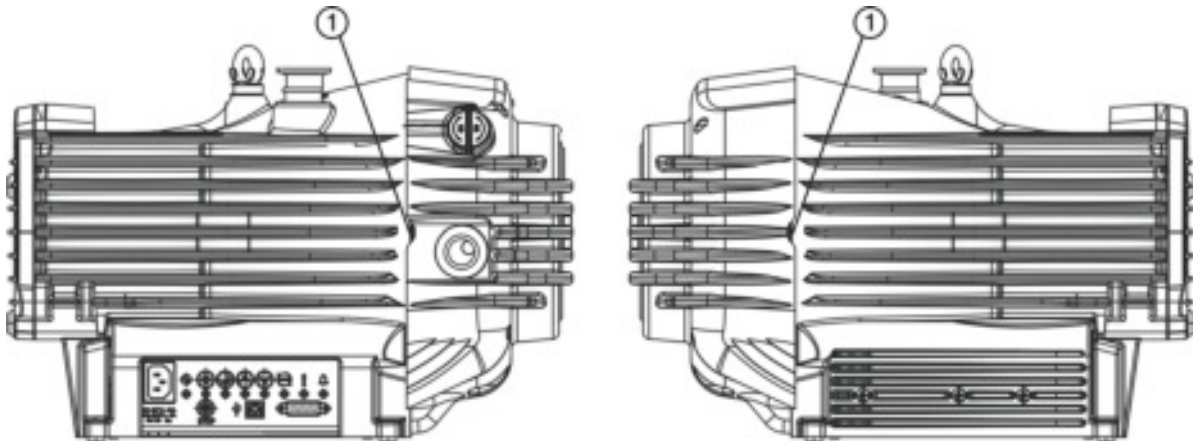

Figure 5 - Motor fan lead connector

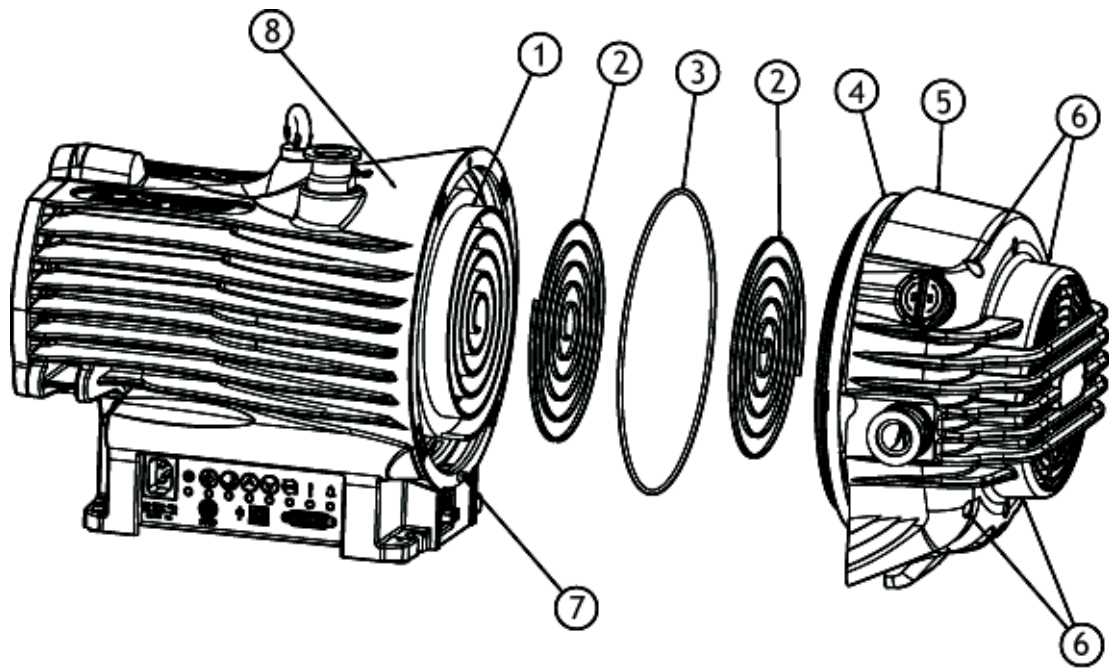

Figure 6 - Pump side views



- 1. Levering slot

Figure 7 - Replacing the tip seals



gea/0082/05/12

1. Orbiting scroll
2. Tip seal
3. Fixed scroll O-ring
4. Fixed scroll
5. Fan-cowl/ fixed scroll assembly
6. Fan-cowl/ fixed scroll fixing screws (4 off)
7. Alignment dowel
8. Housing assembly

This page has been intentionally left blank.